

## Particular Specification

Item No:	BMS-617MG+HS
Weight:	45 grams / 1.60 oz.
Size:	40.5 x 20 x 37 mm / 1.60 x 0.78 x 1.52 in.
Torque At 4.8V:	
Torque At 6.0V:	7.6kg-cm , 110 oz-in
Speed At 4.8V:	
Speed At 6.0V:	0.09 sec / 60° at no load
Ball Bearing:	Dual / M9x7
Metal Gears:	YES, 3 gears of aluminum, 2 gear of copper, 1 nylon gear
Motor Type:	Namiki 3 pole Motor
Operating Voltage Range	4.8V to 6.0V
Operating Temperature Range	-20°C to +60°C
Idle Current	3mA at Stopped
Running Current	700mA
Stall Current	1200mA
Dead Bend Width	2 usec
Direction	Re-clock wise / pulse traveling 1200 to 1600 usec
Horn Gear Spline	25 Segments / (Same as Futaba)
Connector Wire Length	300mm (11.81in)
Connector Horsing	Universal connector
Power Push Chips	Mos-FET ships
Wire Info	Brown Wire = Battery Negative Red Wire = Battery Positive Orange Wire = Signal
PC Board enhance	TVS Interference

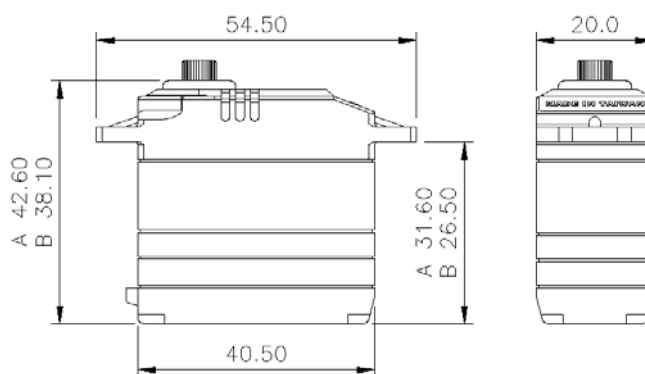

Unit: mm